

Fiche technique du **LEDP60Wxx**



SPECIFICATIONS GENERALES

	LEDP60W60	LEDP60W60ABC	LEDP60W30
Consommation	27 WATT		
Equivalence	300W Halogène		
Température de couleur	5 700K	3 000K	5 700K
Flux lumineux	4300 lm	3800 lm	4300 lm
Efficacité lumineuse	72lm/W	63 lm/W	72lm/W
IRC (Indice de rendu des couleurs)	70	85	70
Angle de diffusion	60°		30°
LED	Philips Lumileds LED		
Tension	100-240 VOLT		
Dimensions	115 x 85 x 85		
Durée de vie	30 000 heures		
Niveau de protection	IP66		
Poids	0,550 kg		
Température de fonctionnement :	-20°C~+40°C		
Garantie	2 ans		
Conditionnement	1 pièce/carton		

Courbes photométriques

LEDP60W60 (Nous consulter pour les autres références)

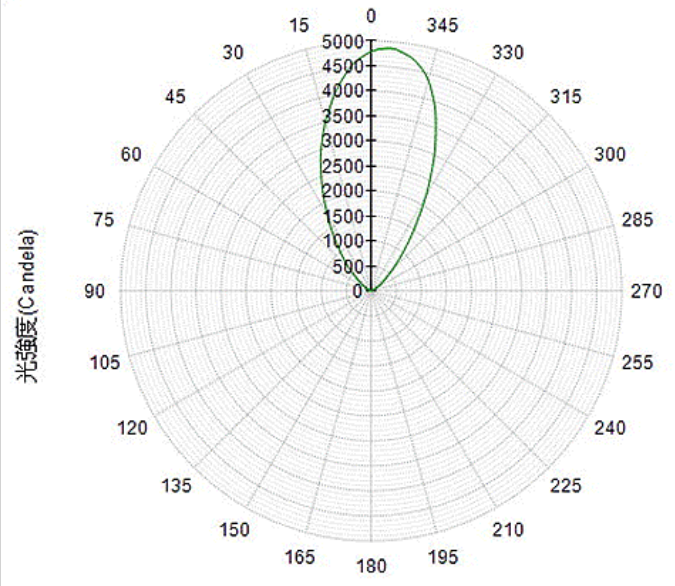
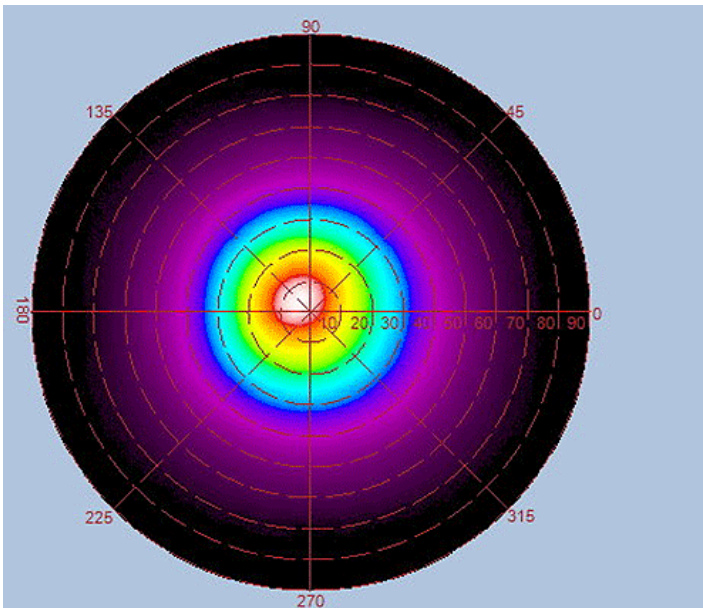

Height	E Max.	Diameter
1.0M	5030 Lx	100 cm
2.0M	1258 Lx	200 cm
3.0M	559 Lx	300 cm
4.0M	314 Lx	400 cm
5.0M	201 Lx	500 cm

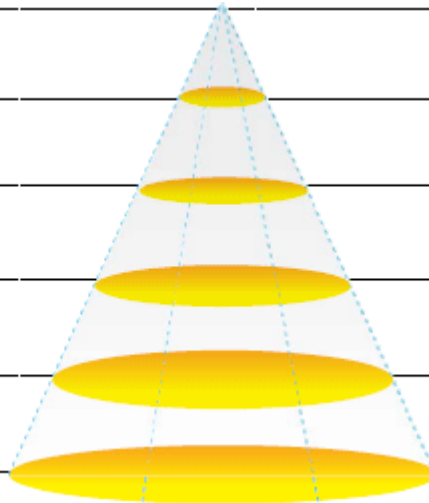

DIMENSIONS

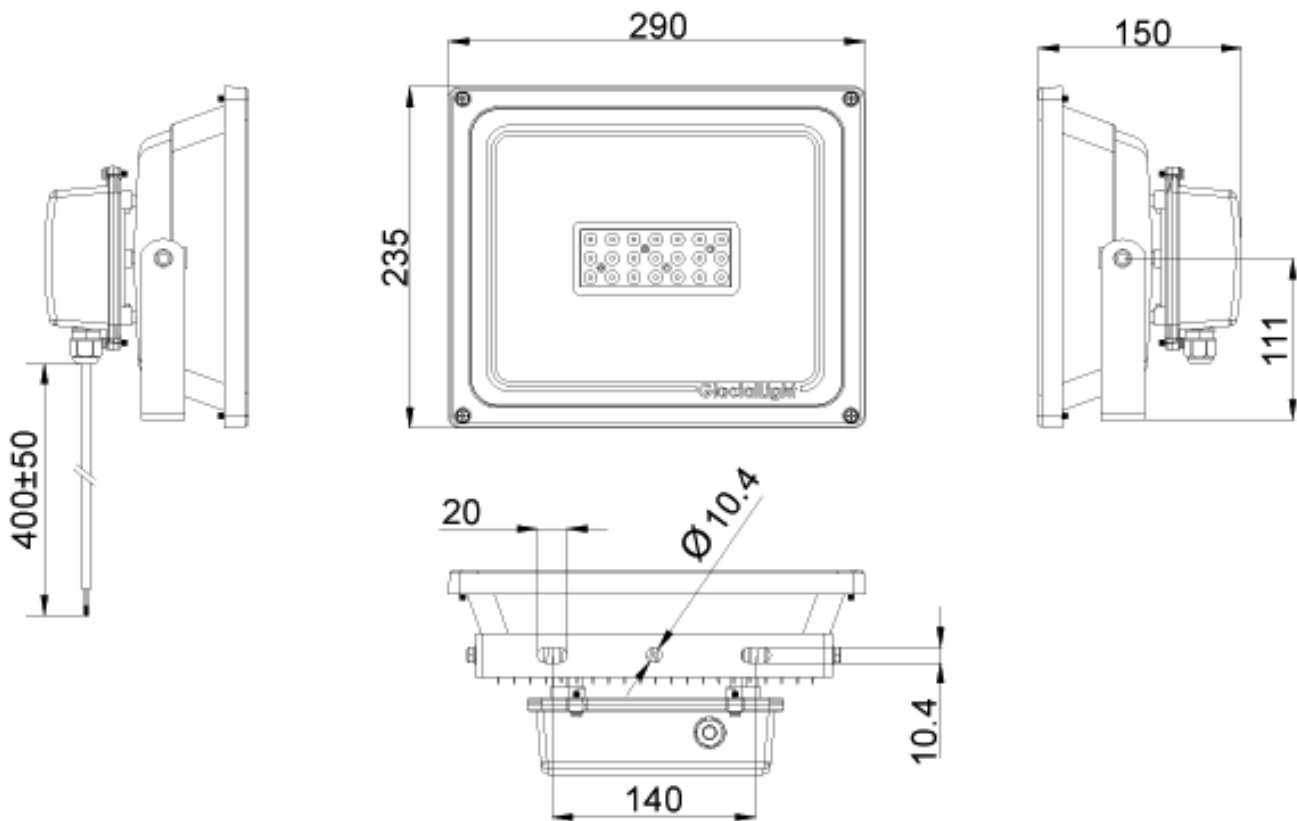

※ UNIT: mm

※ Philips Lumileds LED

OPTION DE POSE

PIQUET DE TERRE :



DIMENSIONS

